

CK, circular duct fan

At the start of the 1980's another revolutionary development of the in-line circular duct fan occurred. AB C.A. Östberg launched a new generation fan which had a new casing design, an innovative motor support with integral guide vanes as well as an improved impeller design. After these changes the result was superior

technical data compared to their competitors (see diagram).

In 1993 Hans Östberg was granted the patent on further improvements (European Patent 0625642), which resulted in higher quality at the same time as reducing the manufacturing costs.

HIGH CAPACITY AND OPERATIONAL SAFETY

High quality, low sound levels, easy installation and well designed useful accessories are some of the hallmarks of the CK in-line circular duct fan.

CK has a backward curved impeller, an external rotor motor and straight-through airflow. It's compact, requires little space for installation and has a high capacity.

The CK fan can cope with high pressure and long duct runs, whilst still operating with a low sound level. The fan speed can easily be controlled by voltage or variable frequency regulators.

The CK is moisture resistant and is approved for installation in humid or damp environments. The fan casing is manufactured from pre-galvanised steel and the motor has in-built protection. The CK can be installed in any position and is rate IP 44 when installed in a duct system.

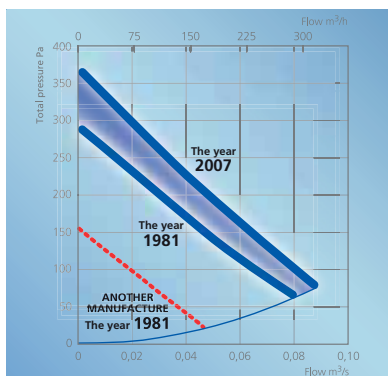

The development of the in-line circular duct fan CK with duct dimension 100 mm. Until the year 1981 the most common model on the market had both low pressure and airflow. In 1981 a superior model was introduced by AB C.A. Östberg which had a much higher pressure and airflow.

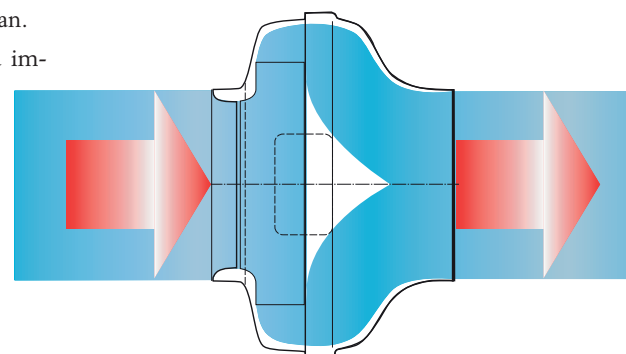

CK 100 A/C

CK 125 A/C

Circular duct fan with backward curved impeller



CK 100 A/C

PRESSURE/FLOW

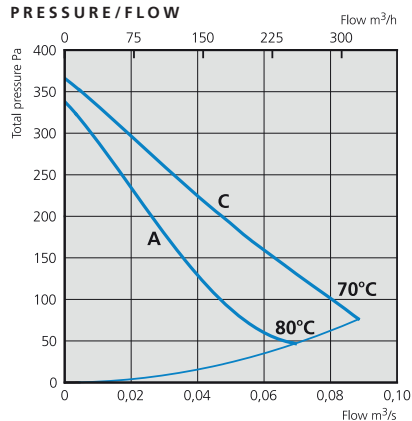

INPUT/FLOW

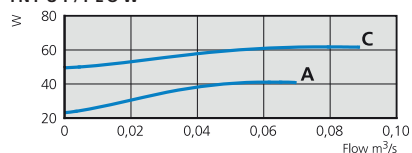

TECHNICAL DATA

CK	100 A	100 C
Voltage, V/Hz	230/50	230/50
Current, A	0,18	0,27
Input, W	41	62
Speed, rpm	1730	2530
Weight, kg	2,9	2,9
Wiring diagram	4040002	4040001
Capacitor, µF	3	2
Insulation class, motor	F	F
Motor protection	IP 44	IP 44

ACCESSORIES

Duct clamp, mounting bracket, safety grille, thermostat, louvre & back draught shutter, transformer controllers

DIMENSIONS (mm)

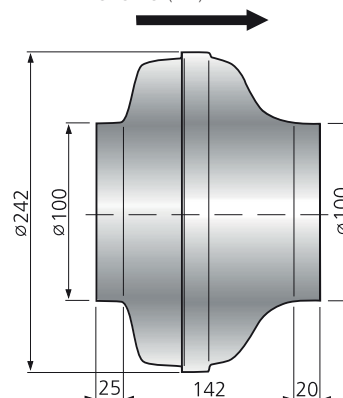

SOUND DATA

CK 100 A, 40 l/s 125 Pa	L _{pA}	L _{wA} tot dB (A)	63	125	250	500	1K	2K	4K	8K
Environment	36	43	35	21	33	35	39	37	37	31
Inlet		66	45	56	64	60	58	52	45	38

CK 100 C, 60 l/s 170 Pa	L _{pA}	L _{wA} tot dB (A)	63	125	250	500	1K	2K	4K	8K
Environment	42	49	34	23	40	40	44	42	44	38
Inlet		70	50	61	66	65	65	59	52	46

General fan facts, page 18-19.

CK 125 A/C

PRESSURE/FLOW

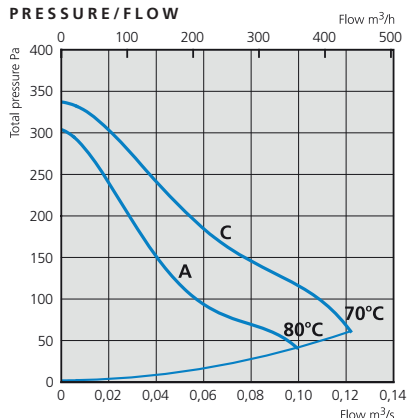

INPUT/FLOW

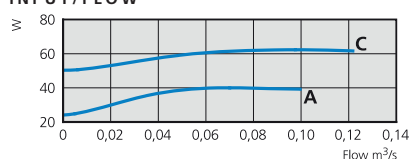

TECHNICAL DATA

CK	125 A	125 C
Voltage, V/Hz	230/50	230/50
Current, A	0,18	0,27
Input, W	40	62
Speed, rpm	1640	2480
Weight, kg	2,9	2,9
Wiring diagram	4040002	4040001
Capacitor, µF	3	2
Insulation class, motor	F	F
Motor protection	IP 44	IP 44

ACCESSORIES

Duct clamp, mounting bracket, safety grille, thermostat, louvre & back draught shutter, transformer controllers

DIMENSIONS (mm)

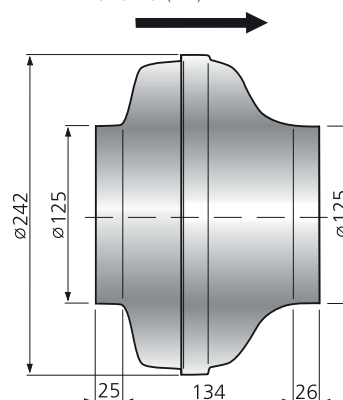

SOUND DATA

CK 125 A, 40 l/s 130 Pa	L _{pA}	L _{wA} tot dB (A)	63	125	250	500	1K	2K	4K	8K
Environment	36	43	35	20	35	34	38	38	36	30
Inlet		67	44	51	66	60	56	52	47	39

CK 125 C, 80 l/s 145 Pa	L _{pA}	L _{wA} tot dB (A)	63	125	250	500	1K	2K	4K	8K
Environment	42	49	36	25	39	39	44	43	45	36
Inlet		70	49	55	64	67	64	60	55	48

General fan facts, page 18-19.



CK 150 B/C CK 160 B/C

Circular duct fan with backward curved impeller

CK 150 B/C

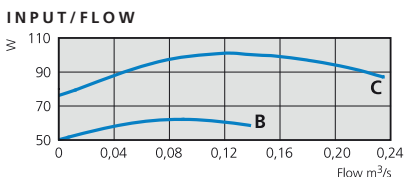
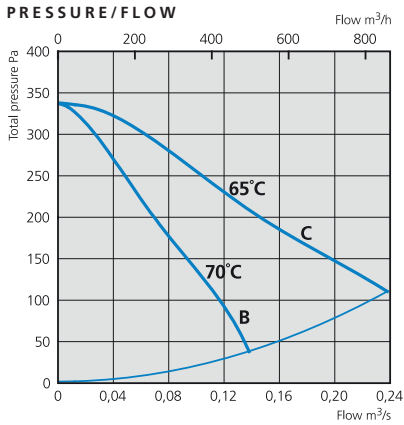

TECHNICAL DATA

CK	150 B	150 C
Voltage, V/Hz	230/50	230/50
Current, A	0,27	0,44
Input, W	62	101
Speed, rpm	2540	2480
Weight, kg	3,2	4,3
Wiring diagram	4040001	4040001
Capacitor, μ F	2	3
Insulation class, motor	F	F
Motor protection	IP 44	IP 44

ACCESSORIES

Duct clamp, mounting bracket, safety grille, thermostat, louvre & back draught shutter, transformer controllers

SOUND DATA

CK 150 B, 70 l/s 195 Pa	L _{pA}	L _{wA} tot dB (A)	63	125	250	500	1K	2K	4K	8K
Environment	42	49	35	24	39	40	45	44	44	32
Inlet		69	48	54	64	65	63	58	53	48

CK 150 C, 160 l/s 190 Pa	L _{pA}	L _{wA} tot dB (A)	63	125	250	500	1K	2K	4K	8K
Environment	49	56	35	34	42	49	54	47	48	35
Inlet		73	52	60	64	68	69	64	64	54

General fan facts, page 18-19.

DIMENSIONS (mm)

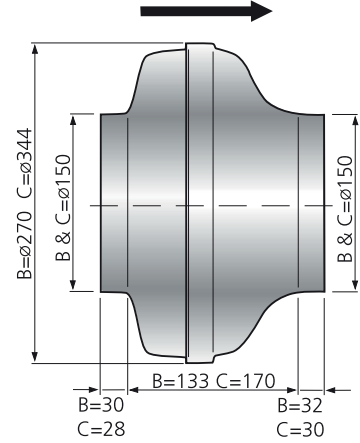

CK 160 B/C

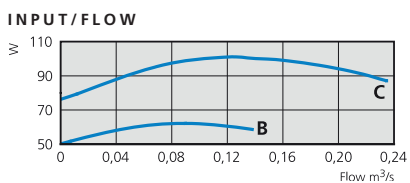
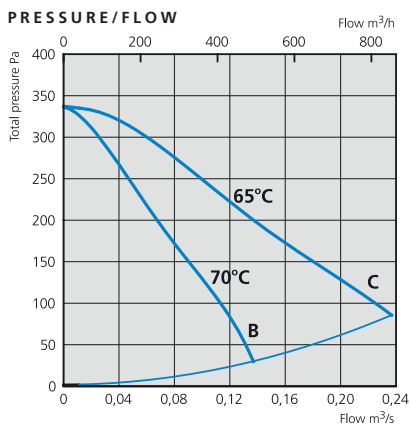

TECHNICAL DATA

CK	160 B	160 C
Voltage, V/Hz	230/50	230/50
Current, A	0,27	0,44
Input, W	62	101
Speed, rpm	2540	2480
Weight, kg	3,2	4,3
Wiring diagram	4040001	4040001
Capacitor, μ F	2	3
Insulation class, motor	F	F
Motor protection	IP 44	IP 44

ACCESSORIES

Duct clamp, mounting bracket, safety grille, thermostat, louvre & back draught shutter, transformer controllers

SOUND DATA

CK 160 B, 70 l/s 195 Pa	L _{pA}	L _{wA} tot dB (A)	63	125	250	500	1K	2K	4K	8K
Environment	42	49	35	24	39	40	45	44	44	32
Inlet		69	48	54	64	65	63	58	53	48

CK 160 C, 160 l/s 190 Pa	L _{pA}	L _{wA} tot dB (A)	63	125	250	500	1K	2K	4K	8K
Environment	49	56	35	34	42	49	54	47	48	35
Inlet		73	52	60	64	68	69	64	64	54

General fan facts, page 18-19.

DIMENSIONS (mm)

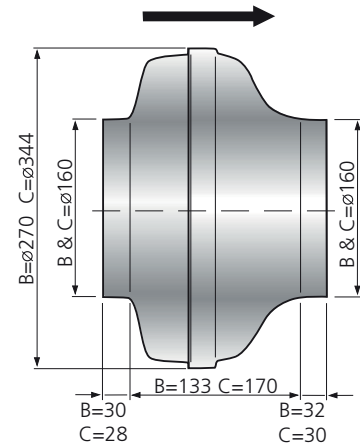

CK 200 A/B CK 250 A/C

Circular duct fan with backward curved impeller



CK 200 A/B

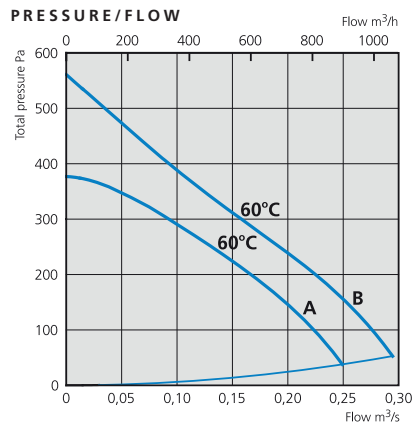

TECHNICAL DATA

CK	200 A	200 B
Voltage, V/Hz	230/50	230/50
Current, A	0,51	0,71
Input, W	115	165
Speed, rpm	2580	2500
Weight, kg	4,6	5,1
Wiring diagram	4040001	4040001
Capacitor, μF	4	4
Insulation class, motor	F	F
Motor protection	IP 44	IP 44

DIMENSIONS (mm)

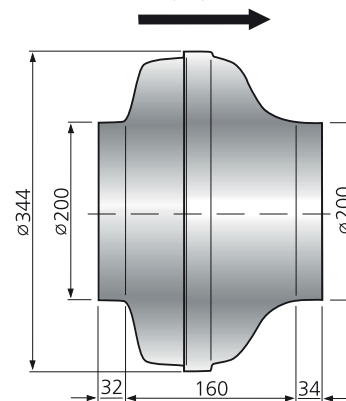

ACCESSORIES

Duct clamp, mounting bracket, safety grille, thermostat, louvre & back draught shutter, transformer controllers

INPUT/FLOW

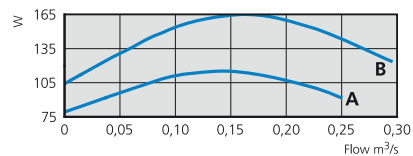

SOUND DATA

CK 200 A, 190 l/s 190 Pa	L _{pA}	L _{wA} tot dB (A)	63	125	250	500	1K	2K	4K	8K
Environment	47	54	34	31	42	46	50	47	48	34
Inlet		72	52	60	64	67	66	64	65	55

CK 200 B, 160 l/s 300 Pa	L _{pA}	L _{wA} tot dB (A)	63	125	250	500	1K	2K	4K	8K
Environment	48	55	35	30	40	48	52	48	49	41
Inlet		73	52	62	66	67	66	65	64	58

General fan facts, page 18-19.

CK 250 A/C

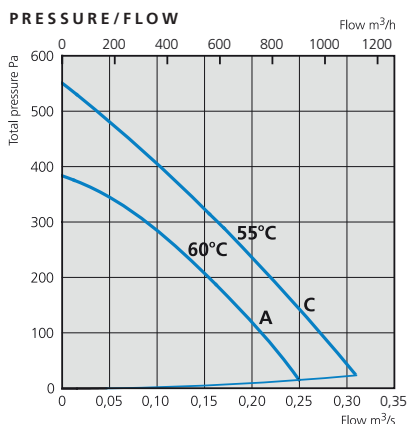

TECHNICAL DATA

CK	250 A	250 C
Voltage, V/Hz	230/50	230/50
Current, A	0,50	0,81
Input, W	115	185
Speed, rpm	2580	2420
Weight, kg	4,6	5,3
Wiring diagram	4040001	4040001
Capacitor, μF	4	5
Insulation class, motor	F	F
Motor protection	IP 44	IP 44

DIMENSIONS (mm)

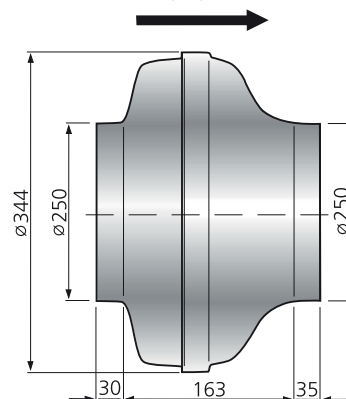

ACCESSORIES

Duct clamp, mounting bracket, safety grille, thermostat, louvre & back draught shutter, transformer controllers

INPUT/FLOW

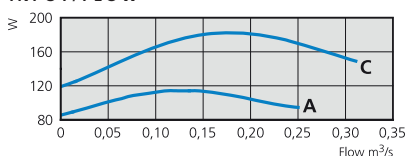

SOUND DATA

CK 250 A, 135 l/s 250 Pa	L _{pA}	L _{wA} tot dB (A)	63	125	250	500	1K	2K	4K	8K
Environment	47	54	26	30	34	47	52	47	44	38
Inlet		74	51	60	67	67	69	68	64	55

CK 250 C, 160 l/s 320 Pa	L _{pA}	L _{wA} tot dB (A)	63	125	250	500	1K	2K	4K	8K
Environment	49	56	26	38	40	50	53	49	46	40
Inlet		74	52	59	66	67	69	69	66	60

General fan facts, page 18-19.



CK 315 B/C

Circular duct fan with backward curved impeller

CK 315 B/C

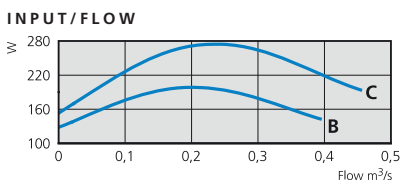
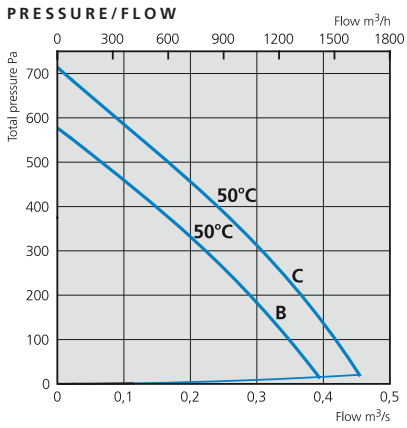

TECHNICAL DATA

CK	315 B	315 C
Voltage, V/Hz	230/50	230/50
Current, A	0,84	1,19
Input, W	190	274
Speed, rpm	2465	2500
Weight, kg	6,1	6,5
Wiring diagram	4040001	4040001
Capacitor, μ F	5	8
Insulation class, motor	F	F
Motor protection	IP 44	IP 44

ACCESSORIES

Duct clamp, mounting bracket, safety grille, thermostat, louvre & back draught shutter, transformer controllers

DIMENSIONS (mm)

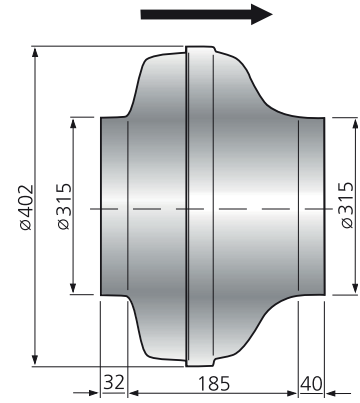

SOUND DATA

CK 315 B, 220 l/s 300 Pa	L_{pA}	L_{wA} tot dB (A)	63	125	250	500	1K	2K	4K	8K
Environment	47	54	28	35	43	48	49	50	45	41
Inlet		74	54	56	61	65	65	70	67	65

CK 315 C, 180 l/s 425 Pa	L_{pA}	L_{wA} tot dB (A)	63	125	250	500	1K	2K	4K	8K
Environment	50	57	30	35	44	51	51	53	50	43
Inlet		75	58	60	67	66	66	72	68	66

General fan facts, page 18-19.

CK 100 A/C 220/60 HZ CK 125 A/C 220/60 HZ

Circular duct fan with backward curved impeller



CK 100 A/C 60 HZ

PRESSURE/FLOW

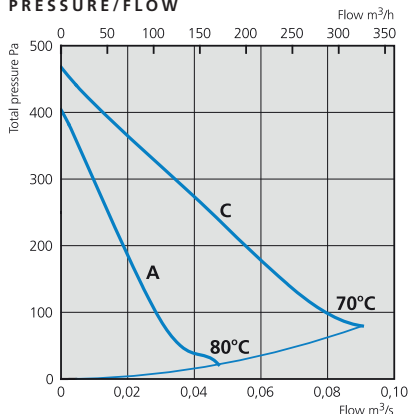

INPUT/FLOW

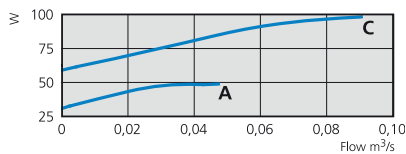

TECHNICAL DATA

CK	100 A	100 C
Voltage, V/Hz	220/60	220/60
Current, A	0,21	0,42
Input, W	45	91
Speed, rpm	1530	2700
Weight, kg	2,9	2,9
Wiring diagram	4040002	4040001
Capacitor, µF	3	2
Insulation class, motor	F	F
Motor protection	IP 44	IP 44

ACCESSORIES

Duct clamp, mounting bracket, safety grille, thermostat, louvre & back draught shutter, transformer controllers

DIMENSIONS (mm)

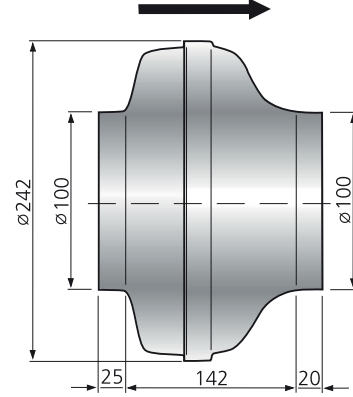

SOUND DATA

CK 100 A, 42 l/s 36 Pa	L _{pA}	L _{wA} tot dB (A)	63	125	250	500	1K	2K	4K	8K
Environment	33	40	23	28	29	31	37	33	27	25
Inlet		58	35	51	52	51	50	45	43	23

CK 100 C, 72 l/s 125 Pa	L _{pA}	L _{wA} tot dB (A)	63	125	250	500	1K	2K	4K	8K
Environment	45	52	25	31	40	40	48	46	41	40
Inlet		72	47	64	65	66	65	63	57	48

General fan facts, page 18-19.

CK 125 A/C 60 HZ

PRESSURE/FLOW

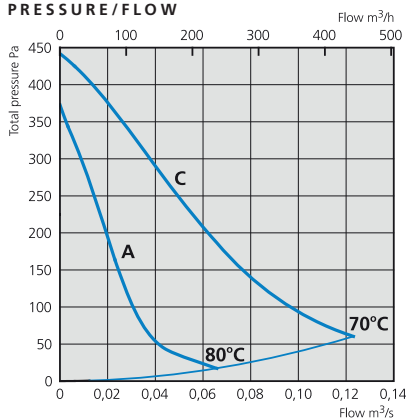

INPUT/FLOW

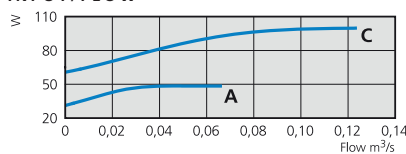

TECHNICAL DATA

CK	125 A	125 C
Voltage, V/Hz	220/60	220/60
Current, A	0,21	0,44
Input, W	45	95
Speed, rpm	1435	2510
Weight, kg	2,9	2,9
Wiring diagram	4040002	4040001
Capacitor, µF	3	2
Insulation class, motor	F	F
Motor protection	IP 44	IP 44

ACCESSORIES

Duct clamp, mounting bracket, safety grille, thermostat, louvre & back draught shutter, transformer controllers

DIMENSIONS (mm)

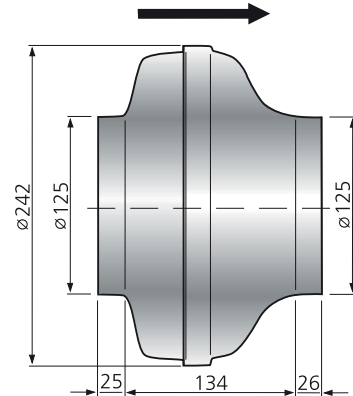

SOUND DATA

CK 125 A, 44 l/s 43 Pa	L _{pA}	L _{wA} tot dB (A)	63	125	250	500	1K	2K	4K	8K
Environment	31	38	22	28	30	30	32	30	26	24
Inlet		56	39	46	50	52	48	44	39	23

CK 125 C, 84 l/s 128 Pa	L _{pA}	L _{wA} tot dB (A)	63	125	250	500	1K	2K	4K	8K
Environment	45	52	25	34	40	40	47	43	47	37
Inlet		71	50	60	63	67	64	63	58	51

General fan facts, page 18-19.



CK 150 B/C 220/60 HZ

CK 160 B/C 220/60 HZ

Circular duct fan with backward curved impeller

CK 150 B/C 60 HZ

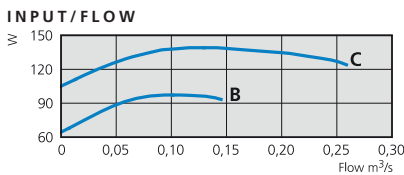
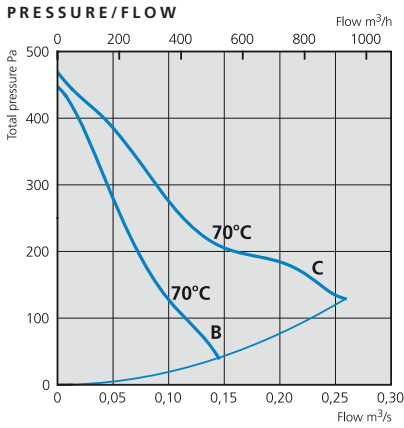

TECHNICAL DATA

CK	150 B	150 C
Voltage, V/Hz	220/60	220/60
Current, A	0,43	0,60
Input, W	93	131
Speed, rpm	2585	2555
Weight, kg	3,2	4,3
Wiring diagram	4040001	4040001
Capacitor, μ F	2	3
Insulation class, motor	F	F
Motor protection	IP 44	IP 44

ACCESSORIES

Duct clamp, mounting bracket, safety grille, thermostat, louvre & back draught shutter, transformer controllers

DIMENSIONS (mm)

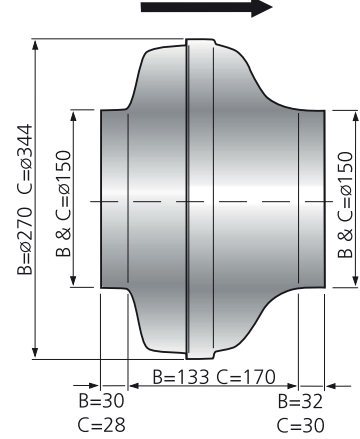

SOUND DATA

CK 150 B, 96 l/s 135 Pa	L_{pA}	L_{wA} tot dB (A)	63	125	250	500	1K	2K	4K	8K
Environment	46	53	23	36	38	42	49	48	39	29
Inlet		70	44	56	63	66	63	60	53	47

CK 150 C, 105 l/s 266 Pa	L_{pA}	L_{wA} tot dB (A)	63	125	250	500	1K	2K	4K	8K
Environment	49	56	24	41	43	48	53	46	47	32
Inlet		75	51	68	70	69	67	64	61	50

General fan facts, page 18-19.

CK 160 B/C 60 HZ

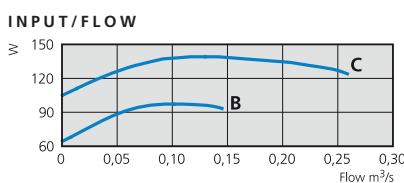
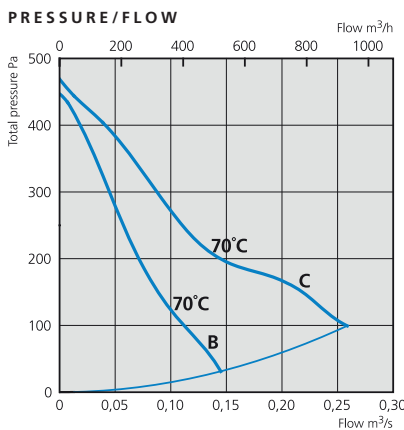

TECHNICAL DATA

CK	160 B	160 C
Voltage, V/Hz	220/60	220/60
Current, A	0,43	0,60
Input, W	93	131
Speed, rpm	2585	2555
Weight, kg	3,2	4,3
Wiring diagram	4040001	4040001
Capacitor, μ F	2	3
Insulation class, motor	F	F
Motor protection	IP 44	IP 44

ACCESSORIES

Duct clamp, mounting bracket, safety grille, thermostat, louvre & back draught shutter, transformer controllers

DIMENSIONS (mm)

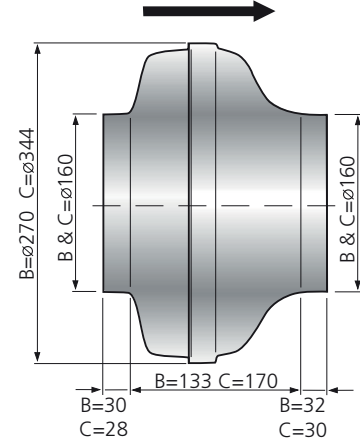

SOUND DATA

CK 160 B, 96 l/s 131 Pa	L_{pA}	L_{wA} tot dB (A)	63	125	250	500	1K	2K	4K	8K
Environment	46	53	23	36	38	42	49	48	39	29
Inlet		70	44	56	63	66	63	60	53	47

CK 160 C, 105 l/s 260 Pa	L_{pA}	L_{wA} tot dB (A)	63	125	250	500	1K	2K	4K	8K
Environment	49	56	24	41	43	48	53	46	47	32
Inlet		75	51	68	70	69	67	64	61	50

General fan facts, page 18-19.

CK 200 A/B 220/60 HZ CK 250 A/C 220/60 HZ

Circular duct fan with backward curved impeller



CK 200 A/B 60 HZ

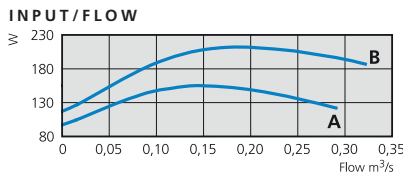
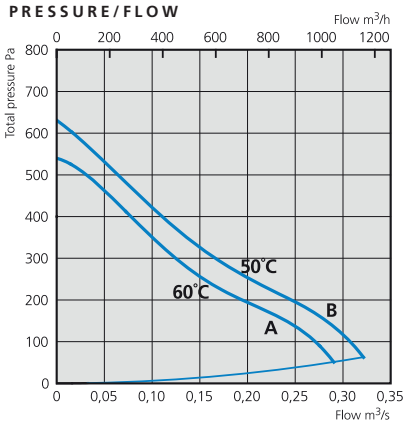

TECHNICAL DATA

CK	200 A	200 B
Voltage, V/Hz	220/60	220/60
Current, A	0,71	0,97
Input, W	154	211
Speed, rpm	2750	2730
Weight, kg	4,6	5,1
Wiring diagram	4040001	4040001
Capacitor, μ F	4	5
Insulation class, motor	F	F
Motor protection	IP 44	IP 44

ACCESSORIES

Duct clamp, mounting bracket, safety grille, thermostat, louvre & back draught shutter, transformer controllers

DIMENSIONS (mm)

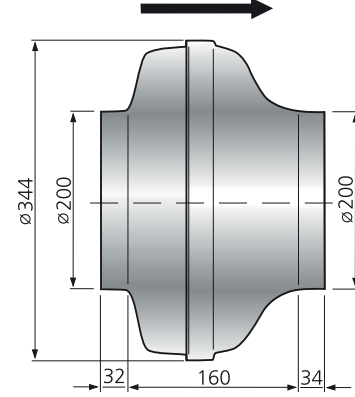

SOUND DATA

CK 200 A, 188 l/s 206 Pa	L _{pA}	L _{wA} tot dB (A)	63	125	250	500	1K	2K	4K	8K
Environment	48	55	22	32	37	47	51	47	48	33
Inlet		76	54	62	70	72	69	65	63	56

CK 200 B, 155 l/s 253 Pa	L _{pA}	L _{wA} tot dB (A)	63	125	250	500	1K	2K	4K	8K
Environment	50	57	26	39	44	51	53	48	44	38
Inlet		78	56	67	73	71	69	66	70	61

General fan facts, page 18-19.

CK 250 A/C 60 HZ

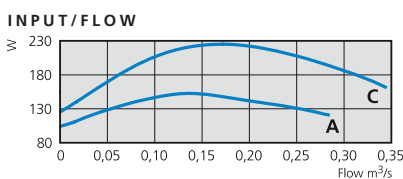
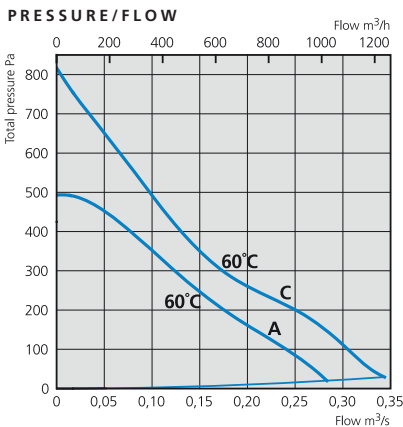

TECHNICAL DATA

CK	250 A	250 C
Voltage, V/Hz	220/60	220/60
Current, A	0,71	1,00
Input, W	154	217
Speed, rpm	2760	2645
Weight, kg	4,6	5,3
Wiring diagram	4040001	4040001
Capacitor, μ F	4	4
Insulation class, motor	F	F
Motor protection	IP 44	IP 44

ACCESSORIES

Duct clamp, mounting bracket, safety grille, thermostat, louvre & back draught shutter, transformer controllers

DIMENSIONS (mm)

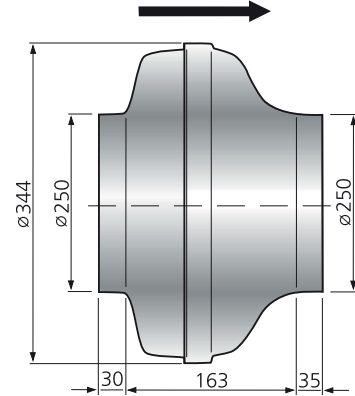

SOUND DATA

CK 250 A, 196 l/s 168 Pa	L _{pA}	L _{wA} tot dB (A)	63	125	250	500	1K	2K	4K	8K
Environment	50	57	22	30	40	51	51	53	49	34
Inlet		77	53	59	67	69	73	68	67	59

CK 250 C, 194 l/s 269 Pa	L _{pA}	L _{wA} tot dB (A)	63	125	250	500	1K	2K	4K	8K
Environment	49	56	32	36	37	49	53	47	44	35
Inlet		75	54	56	63	67	69	69	67	65

General fan facts, page 18-19.



CK 315 B/C 220/60 HZ

Circular duct fan with backward curved impeller

CK 315 B/C 60 HZ

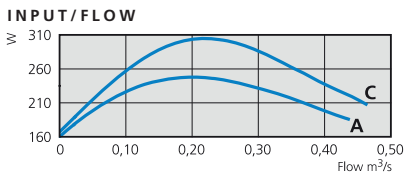
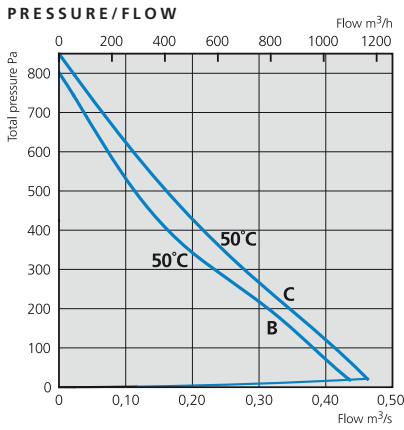

TECHNICAL DATA

CK	315 B	315 C
Voltage, V/Hz	220/60	220/60
Current, A	1,13	1,40
Input, W	247	304
Speed, rpm	2500	2655
Weight, kg	6,1	6,5
Wiring diagram	4040001	4040001
Capacitor, μ F	5	8
Insulation class, motor	F	F
Motor protection	IP 44	IP 44

ACCESSORIES

Duct clamp, mounting bracket, safety grille, thermostat, louvre & back draught shutter, transformer controllers

DIMENSIONS (mm)

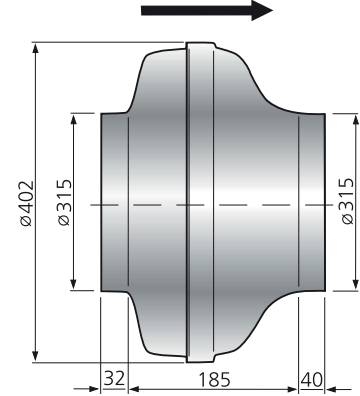

SOUND DATA

CK 315 B, 225 l/s 310 Pa	L_{pA}	L_{wA}	tot dB (A)	63	125	250	500	1K	2K	4K	8K
Environment	49	56	26	47	42	47	50	52	44	32	
Inlet		73	55	59	61	64	66	68	67	61	

CK 315 C, 242 l/s 357 Pa	L_{pA}	L_{wA}	tot dB (A)	63	125	250	500	1K	2K	4K	8K
Environment	50	57	28	37	40	50	52	53	45	34	
Inlet		73	56	61	63	64	65	67	66	60	

General fan facts, page 18-19.